

ABRA 3020

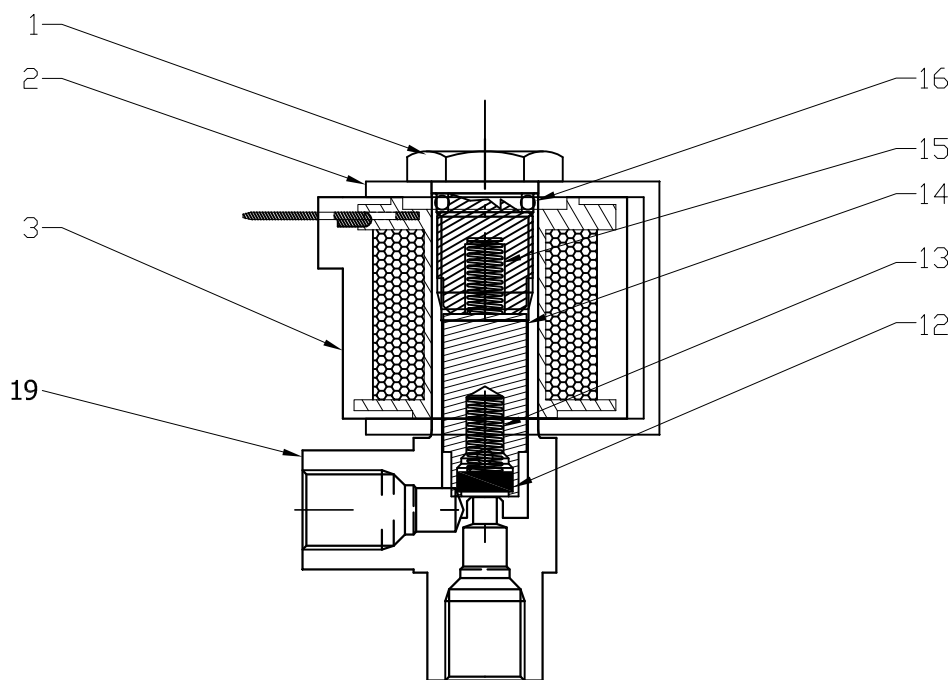

19	1	body without filter / telo ventilu bez filtru	1M2B-1-9-19-1			
16	1	O-ring 9.00 x 1.8 NBR 70 mat.RUB 45700, 75 IRHD	ISO 3601			
14	1	core of LPG valve	design 2N-1-14			
13,15	2	spring of valves 0.5 x 4.4 x 14.4 x 13.5	design 2-1-13			
12	1	rubber sit in	design 2-2-12 / 0081			
3	1	coil of valve 12V 10W	design 2-0-3			
2	1	valve holder	design 2-1-2			
1	1	screw LPG OK17	design 2-1-1			
Itemref	Quantity	Title/Name, designation, material, dimension etc	Article No./Reference			
Designed by Lichovnik		Checked by	Approved by - date	File name magic2 homolog	Date 17/2/2015	Scale
HL propan			Magic - LPG shut off valve			
			1M2B-0-9-1	Edition 1	Sheet 10	

C:\dokumenty\výroba\01M_reduktory lité - MAGIC1_2\01M red\MAGIC 1 2005\MAGIC2 homolog 2005.dwg